

CUT BEND ROLL PUNCH

the **complete**
range of **solution**

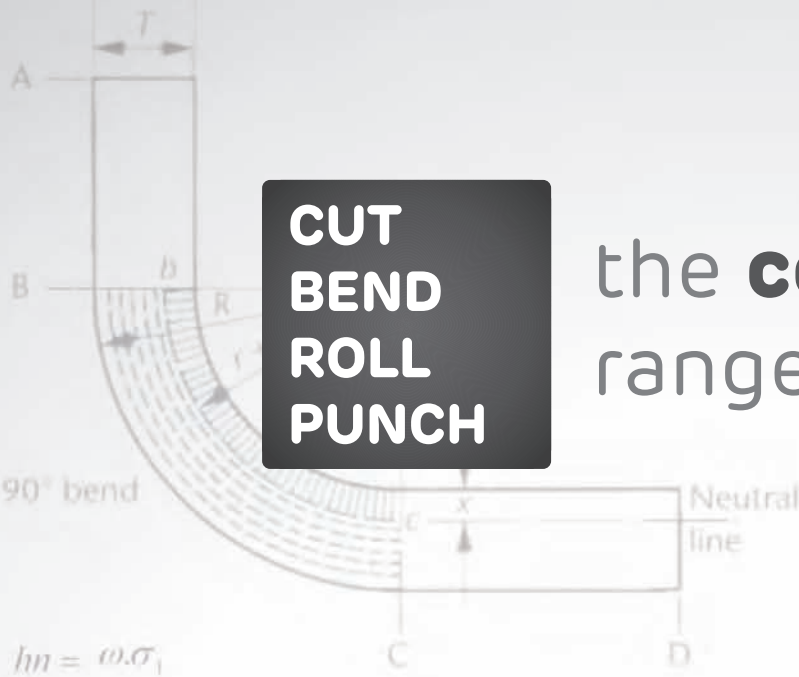

$$\begin{aligned}
 hn &= \omega \cdot \sigma_1 \\
 k'n &= \omega \cdot KN \\
 k'l' &= \rho \cdot c \\
 hn &= \sigma_y \cdot mn \\
 mn &= P_{\eta\eta} \cdot k'l' - Q_{\eta\eta} \cdot k'n \\
 mn &= P_{\eta\eta} \cdot \rho \cdot c - Q_{\eta\eta} \cdot \omega \cdot KN \\
 \omega &= \frac{P_{\eta\eta} \cdot \rho \cdot c}{\sigma_1 + Q_{\eta\eta} \cdot KN}
 \end{aligned}$$

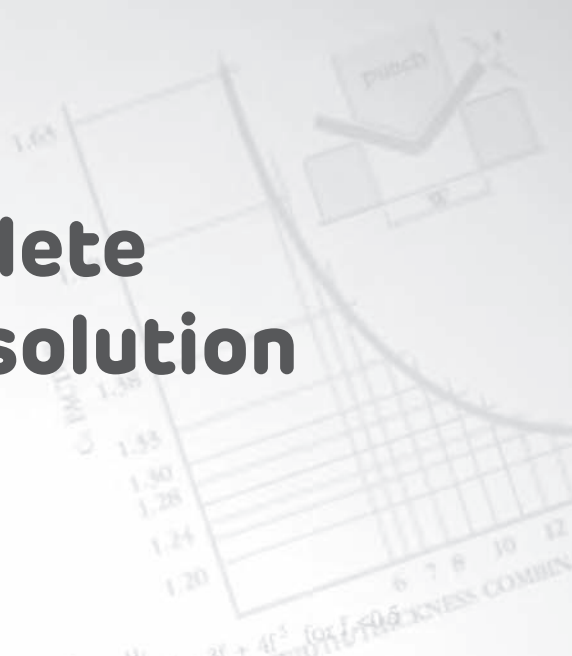

www.**energymission**.com

CNC PRESS BRAKE

SCAN FOR LIVE CHAT



ENERGYMISSION
MACHINERIES (INDIA) PVT. LTD.



Energy Mission Machineries (India) Pvt. Ltd. was established in 1999 with strong vision to deliver most reliable & economical solutions in sheet metal industry. Today Energy Mission is one of the fastest growing company with maximum satisfied customer base in India and Abroad.

WE ARE LEADING MANUFACTURER OF

- ◆ CNC Servo Hybrid & Synchro Press Brakes
- ◆ NC / Conventional Hydraulic Press Brakes
- ◆ CNC / NC / Conventional Hydraulic Shearing Machines
- ◆ Four / Three Roll Plate Rolling Machines
- ◆ Hydraulic Iron Workers
- ◆ Hydraulic / NC Busbar Cutting, Bending & Punching Machines
- ◆ Single / Double / Triple Action Deep Drawing Presses
- ◆ CNC Servo H & C Type Presses
- ◆ Punching & Blanking Hydraulic Presses
- ◆ CNC V Grooving Machines

OUR STRENGTH

- ◆ 22 years of Experience in Manufacturing
- ◆ World Class manufacturing facility spread in 2,50,000 sq.ft
- ◆ Production capacity of 1200 machines per annum
- ◆ More than 5000+ installation across India & Abroad
- ◆ Trained & qualified team of 350 employees
- ◆ Dedicated team for design & development
- ◆ Sales & service network all over India
- ◆ Keen quality control on each component & process
- ◆ Awarded as "Outstanding Entrepreneur of Year" in Year 2008-09 & Year 2014-15

OUR VISION

We at "Energy Mission" believe to deliver high quality products at competitive price supported by best service support. To achieve this mission, we have developed in-house manufacturing facilities, focused manufacturing processes with in-depth technology know-how, sales network associates across India & abroad. Enthusiastic team of customer care is always ready to rush within shortest time at the doorstep of customer or any requirements. Our skilled workforce has a proven performance record in satisfying diverse needs of customers around the globe.

MANUFACTURING FACILITY



FLOOR BORING MACHINE

- ♦ In house single reference machining Facility ensures required quality parameters.
- ♦ CNC Floor Boring machines with Traverse Travel of 9 mtr & 8 mtr.
- ♦ Heavy duty 360° Machining position Rotary table

CNC TURNING & VERTICAL MILLING CENTRE

- ♦ High-tech CNC lathe with 8 station turret for precise cylinder component machining
- ♦ CNC Vertical milling machine with 24 stations auto Turret
- ♦ CNC boring machine suitable for Concave & Convex shapes machining.



CNC PLANO MILLER

- ♦ CNC Plano Milling machines Up to 6 meter bed length
- ♦ Multiple head Single reference Machining
- ♦ Accurate, repetitive & fast operation reduces Production time & cost

INFRASTRUCTURE



CNC PLASMA CUTTING

- ◆ Precise & Fast CNC plasma cutting with X & Y controlled axis suitable for 4 mtr wide & 13 mtr long plates.
- ◆ Precise & accurate cutting accelerates manufacturing process.
- ◆ Inbuilt Nesting Facility to reduce wastage & production time

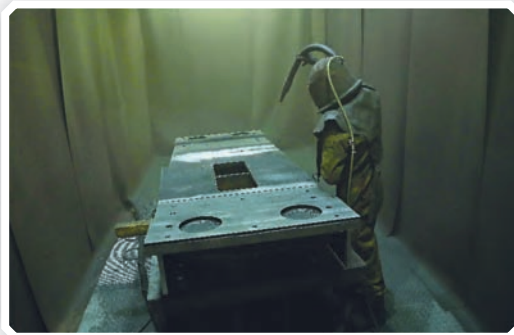

SHOT BLASTING UNIT

- ◆ Environment Friendly surface preparation Facility to remove rust and corrosive materials from the surface
- ◆ Capacity to handle up to 7 mtr. Long Plates & Assembly Structures

PAINT BOOTH UNIT

- ◆ Cross Draft type Paint booth facility to make painting & refinishing parts & Fabricated structures
- ◆ Suitable for 10 Mtr. Long Plates & Assembly Structures



CNC PRESS BRAKE

RANGE 30 MT to 2000 MT
LENGTH 1250 mm to 10000 mm

EFFICIENT SERIES

SALIENT FEATURES

- ♦ 3 Axis machine with automatic, accurate & fast back gauge
- ♦ CybTouch 8PS Controller from CYBELEC Switzerland
- ♦ Rigid upper beam guide on 12-point roller bearings
- ♦ Ultrasonically & tensile tested IS:2062 grade steel structure ensures the rigidity & avoid deflection.
- ♦ The frame is machined on Floor Boring Machine ensuring single reference accurate machining.
- ♦ Quick release clamps
- ♦ Back gauge assembly included ball screw, AC Servo drive, LM guides & timer belt
- ♦ Back gauge fingers mounted on LM guide
- ♦ Quick 'V' groove change over with self centred die with rail.
- ♦ Hardened & grounded 2'V' / 4'V' die & semi gooseneck punch
- ♦ Front sliding sheet support with LM guides for easy movement

ACCURACIES

- ♦ Press Beam Depth Accuracy : $\pm 0.01\text{mm}$
- ♦ Press Beam Depth Repeatability : $\pm 0.01\text{mm}$
- ♦ Back Gauge Accuracy : $\pm 0.1\text{mm}$
- ♦ Back Gauge Repeatability : $\pm 0.1\text{mm}$



ACCURATE
RELIABLE
CONSISTENT



CNC PRESS BRAKE

RANGE | 30 MT to 325 MT
LENGTH | 1250 mm to 10000 mm

SPLENDID
SERIES

► SALIENT FEATURES

- ♦ Higher productivity & lesser cycle time by High speed beam movements
- ♦ Energy Efficient - Reduce power consumption by 40% ~ 45%
- ♦ High bending accuracy and repeatability
- ♦ Fast up & down beam speed up to 160 mm/sec, Pressing speed up to 10 mm/sec.
- ♦ 3 Axis machine with automatic, accurate & fast back gauge
- ♦ CybTouch 8PS Controller from CYBELEC Switzerland
- ♦ Very low noise, Silent & smooth machine operation
- ♦ Rigid upper beam guide on 12-point roller bearings
- ♦ The frame is machined on FLOOR BORING MACHINE ensuring single reference accurate machining
- ♦ Stable hydraulic oil temperature ensures consistent accuracy

ACCURACIES

- ♦ Press Beam Depth Accuracy : ± 0.01mm
- ♦ Press Beam Depth Repeatability : ± 0.01mm
- ♦ Back Gauge Accuracy : ± 0.1mm
- ♦ Back Gauge Repeatability : ± 0.1mm



HIGH SPEED
LOW POWER



CNC PRESS BRAKE TECHNICAL SPECIFICATION

| Model | Bending Force M Ton | Bending Length mm | Bending Capacity mm | C | O | Ram Stroke mm | h | T | Main Motor Hp | EFFICIENT | | | SPLENDID | | | L | W | H | X axis Travel mm | R axis Travel mm | Weight (Approx.) kg | |
|----------|------------------------|----------------------|------------------------|------------------|---------------------|------------------|-------------------|--------------------|------------------|--------------------|------------------------|-----------------------|----------------------|------------------------|-----------------------|----------------------|--------------|-------------|---------------------|---------------------|------------------------|--------------|
| | | | | Clear Pass mm | Open Daylight mm | | Table Width mm | Table Height mm | | Throat Depth mm | Approach Speed mm/s | Working Speed mm/s | Return Speed mm/s | Approach Speed mm/s | Working Speed mm/s | Return Speed mm/s | Length mm | Width mm | | | | Height mm |
| | | | | | | | | | | | | | | | | | | | | | | |
| PBE 0315 | 30 | 1500 | 2x1500 | 1250 | 385 | 200 | 90 | 850 | 200 | 3 | 100 | 6 | 65 | 160 | 10 | 160 | 1700 | 1250 | 2000 | 400 | 200 | 2750 |
| PBE 0320 | 30 | 2000 | 1.8x2000 | 1550 | 385 | 200 | 90 | 850 | 200 | 3 | 100 | 6 | 65 | 160 | 10 | 160 | 2200 | 1250 | 2100 | 400 | 200 | 3500 |
| PBE 0415 | 40 | 1500 | 3x1500 | 1250 | 385 | 200 | 90 | 850 | 250 | 5 | 100 | 7 | 80 | 160 | 10 | 160 | 1700 | 1300 | 2100 | 400 | 200 | 3500 |
| PBE 0420 | 40 | 2000 | 2.5x2000 | 1550 | 385 | 200 | 90 | 850 | 250 | 5 | 100 | 7 | 80 | 160 | 10 | 160 | 2200 | 1300 | 2100 | 400 | 200 | 4000 |
| PBE 0425 | 40 | 2500 | 2x2500 | 2050 | 385 | 200 | 90 | 850 | 250 | 5 | 100 | 7 | 80 | 160 | 10 | 160 | 2700 | 1300 | 2200 | 400 | 200 | 4650 |
| PBE 0515 | 50 | 1500 | 3.5x1500 | 1250 | 385 | 200 | 90 | 850 | 250 | 5 | 100 | 7 | 80 | 160 | 10 | 160 | 2000 | 1800 | 2500 | 400 | 200 | 3800 |
| PBE 0520 | 50 | 2000 | 3x2000 | 1550 | 385 | 200 | 90 | 850 | 250 | 5 | 100 | 7 | 80 | 160 | 10 | 160 | 2200 | 1300 | 2200 | 400 | 200 | 4250 |
| PBE 0525 | 50 | 2500 | 2.5x2500 | 2050 | 385 | 200 | 90 | 850 | 250 | 5 | 100 | 7 | 80 | 160 | 10 | 160 | 2700 | 1300 | 2300 | 400 | 200 | 4900 |
| PBE 0531 | 50 | 3100 | 2x3100 | 2600 | 385 | 200 | 90 | 850 | 250 | 5 | 100 | 7 | 80 | 160 | 10 | 160 | 3300 | 1300 | 2300 | 400 | 200 | 5500 |
| PBE 0620 | 65 | 2000 | 3.5x2000 | 1550 | 385 | 200 | 90 | 850 | 250 | 5 | 100 | 7 | 80 | 160 | 10 | 160 | 2200 | 1400 | 2500 | 400 | 200 | 4750 |
| PBE 0625 | 65 | 2500 | 3x2500 | 2050 | 385 | 200 | 90 | 850 | 250 | 5 | 100 | 7 | 80 | 160 | 10 | 160 | 2700 | 1400 | 2500 | 400 | 200 | 5500 |
| PBE 0631 | 65 | 3100 | 2x3100 | 2600 | 385 | 200 | 90 | 850 | 250 | 5 | 100 | 7 | 80 | 160 | 10 | 160 | 3300 | 1400 | 2500 | 400 | 200 | 6350 |
| PBE 0820 | 80 | 2000 | 5x2000 | 1550 | 385 | 200 | 90 | 850 | 250 | 7.5 | 100 | 6 | 80 | 160 | 10 | 160 | 2250 | 1400 | 2600 | 600 | 200 | 5500 |
| PBE 0825 | 80 | 2500 | 4x2500 | 2050 | 385 | 200 | 90 | 850 | 250 | 7.5 | 100 | 6 | 80 | 160 | 10 | 160 | 2750 | 1400 | 2600 | 600 | 200 | 6250 |
| PBE 0831 | 80 | 3100 | 3x3100 | 2600 | 385 | 200 | 90 | 850 | 250 | 7.5 | 100 | 6 | 80 | 160 | 10 | 160 | 3400 | 1400 | 2650 | 600 | 200 | 7000 |
| PBE 0841 | 80 | 4100 | 2x4100 | 3500 | 385 | 200 | 90 | 930 | 250 | 7.5 | 100 | 6 | 80 | 160 | 10 | 160 | 4300 | 1400 | 2800 | 600 | 200 | 8500 |
| PBE 1025 | 100 | 2500 | 5x2500 | 2050 | 485 | 300 | 90 | 850 | 400 | 10 | 100 | 7 | 80 | 160 | 10 | 160 | 2750 | 1650 | 2700 | 600 | 200 | 7000 |
| PBE 1031 | 100 | 3100 | 4x3100 | 2600 | 485 | 300 | 90 | 850 | 400 | 10 | 100 | 7 | 80 | 160 | 10 | 160 | 3400 | 1650 | 3100 | 600 | 200 | 8500 |
| PBE 1041 | 100 | 4100 | 3x4100 | 3500 | 485 | 300 | 90 | 930 | 400 | 10 | 100 | 7 | 80 | 160 | 10 | 160 | 4300 | 1650 | 2900 | 600 | 200 | 10000 |
| PBE 1051 | 100 | 5100 | 2.5x5100 | 4500 | 485 | 300 | 90 | 1000 | 400 | 10 | 100 | 7 | 80 | 160 | 10 | 160 | 5350 | 1650 | 3200 | 600 | 200 | 12500 |
| PBE 1225 | 125 | 2500 | 6x2500 | 2050 | 485 | 300 | 90 | 850 | 400 | 12.5 | 100 | 6 | 65 | 160 | 10 | 160 | 3000 | 2100 | 3000 | 600 | 200 | 7800 |
| PBE 1231 | 125 | 3100 | 5x3100 | 2600 | 485 | 300 | 90 | 850 | 400 | 12.5 | 100 | 6 | 65 | 160 | 10 | 160 | 3500 | 2100 | 3000 | 600 | 200 | 9000 |
| PBE 1241 | 125 | 4100 | 3.5x4100 | 3500 | 485 | 300 | 90 | 995 | 400 | 12.5 | 100 | 6 | 65 | 160 | 10 | 160 | 4500 | 2100 | 3000 | 600 | 200 | 10750 |
| PBE 1251 | 125 | 5100 | 3x5100 | 4500 | 485 | 300 | 90 | 1050 | 400 | 12.5 | 100 | 6 | 65 | 160 | 10 | 160 | 5500 | 2100 | 3000 | 600 | 200 | 14000 |
| PBE 1625 | 160 | 2500 | 8x2500 | 2050 | 485 | 300 | 90 | 850 | 400 | 15 | 100 | 6 | 80 | 160 | 10 | 160 | 2800 | 1800 | 2900 | 600 | 200 | 8000 |
| PBE 1631 | 160 | 3100 | 6x3100 | 2600 | 485 | 300 | 90 | 850 | 400 | 15 | 100 | 6 | 80 | 160 | 10 | 160 | 3400 | 1800 | 3100 | 600 | 200 | 9500 |
| PBE 1641 | 160 | 4100 | 5x4100 | 3500 | 485 | 300 | 90 | 1010 | 400 | 15 | 100 | 6 | 80 | 160 | 10 | 160 | 4300 | 1800 | 3200 | 600 | 200 | 12000 |
| PBE 1651 | 160 | 5100 | 3.5x5100 | 4500 | 485 | 300 | 90 | 1050 | 400 | 15 | 100 | 6 | 80 | 160 | 10 | 160 | 5350 | 1800 | 3400 | 600 | 200 | 16000 |
| PBE 2031 | 200 | 3100 | 8x3100 | 2600 | 485 | 300 | 90 | 850 | 400 | 20 | 100 | 6 | 80 | 160 | 10 | 160 | 3350 | 1900 | 2900 | 600 | 200 | 11000 |
| PBE 2041 | 200 | 4100 | 6x4100 | 3500 | 485 | 300 | 90 | 1000 | 400 | 20 | 100 | 6 | 80 | 160 | 10 | 160 | 4350 | 1900 | 3250 | 600 | 200 | 14000 |
| PBE 2051 | 200 | 5100 | 5x5100 | 4500 | 485 | 300 | 90 | 1050 | 400 | 20 | 100 | 6 | 80 | 160 | 10 | 160 | 5350 | 2000 | 3500 | 600 | 200 | 17000 |
| PBE 2531 | 250 | 3100 | 10x3100 | 2600 | 565 | 350 | 180 | 850 | 450 | 25 | 80 | 6 | 80 | 140 | 8 | 140 | 3350 | 2100 | 2900 | 600 | 200 | 12750 |
| PBE 2541 | 250 | 4100 | 8x4100 | 3500 | 565 | 350 | 180 | 1100 | 450 | 25 | 80 | 6 | 80 | 140 | 8 | 140 | 4350 | 2100 | 3300 | 600 | 200 | 15500 |
| PBE 2551 | 250 | 5100 | 6x5100 | 4500 | 565 | 350 | 180 | 1150 | 450 | 25 | 80 | 6 | 80 | 140 | 8 | 140 | 5350 | 2100 | 3600 | 600 | 200 | 18500 |
| PBE 3231 | 325 | 3100 | 12x3100 | 2600 | 565 | 350 | 180 | 850 | 450 | 25 | 80 | 6 | 80 | 140 | 8 | 140 | 3400 | 2100 | 3200 | 600 | 200 | 16750 |
| PBE 3241 | 325 | 4100 | 10x4100 | 3500 | 565 | 350 | 180 | 1150 | 450 | 25 | 80 | 6 | 80 | 140 | 8 | 140 | 4400 | 2100 | 3400 | 600 | 200 | 19750 |
| PBE 3251 | 325 | 5100 | 8x5100 | 4500 | 565 | 350 | 180 | 1200 | 450 | 25 | 80 | 6 | 80 | 140 | 8 | 140 | 5400 | 2200 | 3750 | 600 | 200 | 24000 |
| PBE 4031 | 400 | 3100 | 16x3100 | 2600 | 600 | 375 | 220 | 950 | 550 | 40 | 75 | 5 | 80 | -- | -- | -- | 3400 | 2200 | 3500 | 600 | 200 | 22000 |
| PBE 4041 | 400 | 4100 | 12x4100 | 3300 | 600 | 375 | 220 | 1200 | 550 | 40 | 75 | 5 | 80 | -- | -- | -- | 4400 | 2200 | 3600 | 600 | 200 | 27000 |
| PBE 4051 | 400 | 5100 | 10x5100 | 4300 | 600 | 375 | 220 | 985+P | 550 | 40 | 75 | 5 | 80 | -- | -- | -- | 5400 | 2400 | 4100 | 600 | 200 | 33000 |
| PBE 4061 | 400 | 6100 | 8x6100 | 5300 | 600 | 375 | 220 | 985+P | 550 | 40 | 75 | 5 | 80 | -- | -- | -- | 6400 | 2500 | 4200 | 600 | 200 | 40000 |
| PBE 5031 | 500 | 3100 | 20x3100 | 2600 | 600 | 375 | 220 | 1020 | 550 | 50 | 75 | 5 | 80 | -- | -- | -- | 3400 | 2200 | 3600 | 600 | 200 | 25000 |
| PBE 5041 | 500 | 4100 | 15x4100 | 3300 | 600 | 375 | 220 | 1200 | 550 | 50 | 75 | 5 | 80 | -- | -- | -- | 4400 | 2200 | 3900 | 600 | 200 | 30000 |
| PBE 5051 | 500 | 5100 | 12x5100 | 4300 | 600 | 375 | 220 | 985+P | 550 | 50 | 75 | 5 | 80 | -- | -- | -- | 5400 | 2400 | 4250 | 600 | 200 | 36000 |
| PBE 5061 | 500 | 6100 | 10x6100 | 5300 | 600 | 375 | 220 | 985+P | 550 | 50 | 75 | 5 | 80 | -- | -- | -- | 6400 | 2500 | 4500 | 600 | 200 | 45000 |

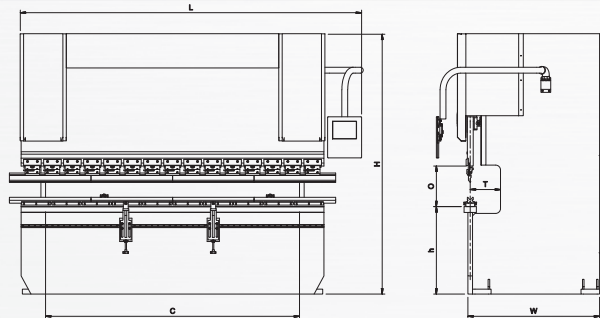

Note :
Other Models are available as
per requirements



CNC PRESS BRAKE

RANGE | 30 MT to 325 MT
LENGTH | 1250 mm to 10000 mm

OPTIMA
SERIES

▶ SALIENT FEATURES

- ♦ Individual servo motor in combination of hyd. Pump controls the accurate positioning of Y1 & Y2 axis
- ♦ Energy Efficient - Reduce power consumption by 45% ~ 50%
- ♦ Fast up & down beam speed up to 220mm/sec, Pressing speed up to 16 mm/sec
- ♦ CybTouch 12PS Controller from CYBELEC Switzerland
- ♦ 4+1 Axis machine with Accurate, high speed backgauge reduces positioning time and easily handles bending of complex parts
- ♦ Rigid upper beam guide on 12-point roller bearings
- ♦ The frame is machined on FLOOR BORING MACHINE ensuring single reference accurate machining
- ♦ Very low noise level, Silent & smooth machine operation
- ♦ Stable hydraulic oil temperature ensures consistent accuracy
- ♦ Lesser oil quantity

ACCURACIES

- ♦ Press Beam Depth Accuracy : ± 0.01mm
- ♦ Press Beam Depth Repeatability : ± 0.01mm
- ♦ Back Gauge Accuracy : ± 0.1mm
- ♦ Back Gauge Repeatability : ± 0.1mm



INTELLIGENT GREEN POWER



STANDARD ACCESSORIES



CybTouch 8PS Controller from CYBELEC Switzerland



Servo hydraulics from HAWE - Germany / ATOS - Italy for Y1-Y2 axis control



- Quick Release Clamp with taper wedges for localized bending degree adjustment.
- Sliding front sheet support on LM guides.



- Self centered Hardened & Grounded Segmented single 'V' / 2 'V' / 4 'V' die & punch.
- Various tool profiles are available as an option.



Back gauge finger movement in Z Axis on LM guide to maintain the parallelism across the table.

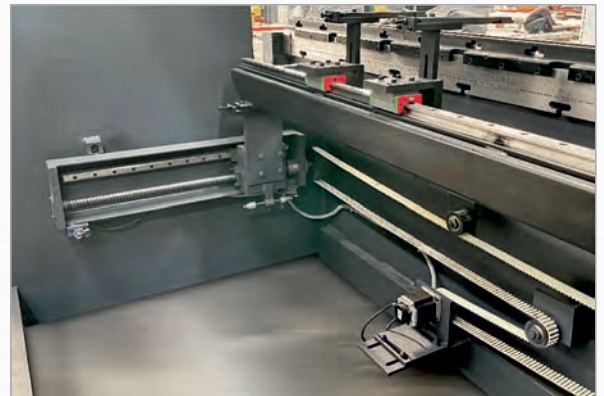

- High speed AC servo driven back gauge equipped with hardened & grounded ball screw with LM guides mounted on heavy fabricated channel housing.
- The timer belt is used for precise synchronized movement to avoid backlash error.

EXCLUSIVE ACCESSORIES FOR OPTIMA



CybTouch 12PS Controller from CYBELEC Switzerland



Automatic Crowning (For L = 2500mm & Higher)

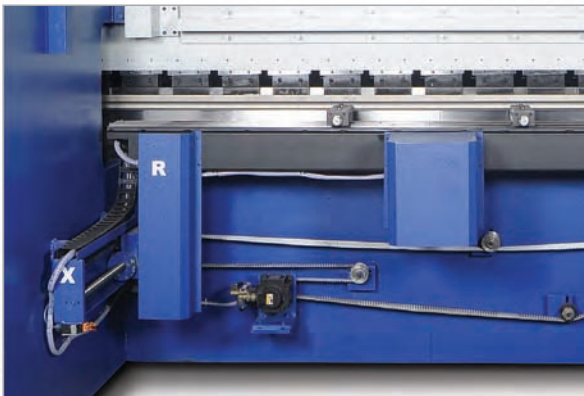

X + R Axis Back Gauge

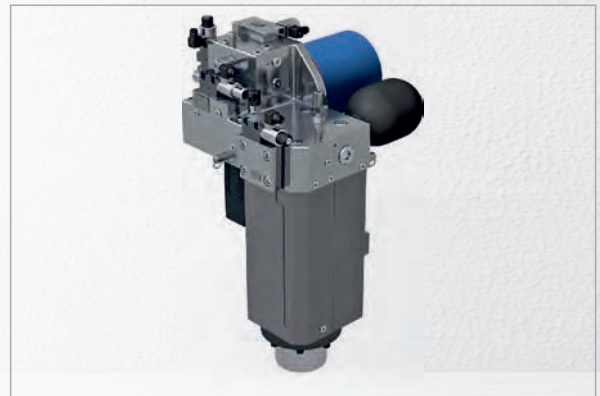

Hydraulic Package with Servo motor for High speed & Power Saving.

TECHNICAL SPECIFICATION FOR OPTIMA

| Model | Bending Force | Bending Length | Bending Capacity | Clear Pass | Open Daylight | Ram Stroke | Throat Depth | Approach Speed | Working Speed | Return Speed |
|----------|---------------|----------------|------------------|------------|---------------|------------|--------------|----------------|---------------|--------------|
| | M Ton | mm | mm | mm | mm | mm | mm | mm/s | mm/s | mm/s |
| PBO 0520 | 50 | 2000 | 3x2000 | 1550 | 385 | 200 | 250 | 200 | 14 | 200 |
| PBO 0525 | 50 | 2500 | 2.5x2500 | 2050 | 385 | 200 | 250 | 200 | 14 | 200 |
| PBO 0625 | 65 | 2500 | 3x2500 | 2050 | 385 | 200 | 250 | 200 | 14 | 200 |
| PBO 0820 | 80 | 2000 | 5x2000 | 1550 | 385 | 200 | 250 | 200 | 14 | 200 |
| PBO 0825 | 80 | 2500 | 4x2500 | 2050 | 385 | 200 | 250 | 200 | 14 | 200 |
| PBO 1025 | 100 | 2500 | 5x2500 | 2050 | 485 | 300 | 400 | 200 | 14 | 200 |
| PBO 1031 | 100 | 3100 | 4x3100 | 2600 | 485 | 300 | 400 | 200 | 14 | 200 |
| PBO 1041 | 100 | 4100 | 3x4100 | 3500 | 485 | 300 | 400 | 200 | 14 | 200 |
| PBO 1231 | 125 | 3100 | 5x3100 | 2600 | 485 | 300 | 400 | 200 | 14 | 200 |
| PBO 1241 | 125 | 4100 | 3.5x4100 | 3500 | 485 | 300 | 400 | 200 | 14 | 200 |
| PBO 1631 | 160 | 3100 | 6x3100 | 2600 | 485 | 300 | 400 | 200 | 14 | 200 |
| PBO 1641 | 160 | 4100 | 5x4100 | 3500 | 485 | 300 | 400 | 200 | 14 | 200 |
| PBO 2031 | 200 | 3100 | 8x3100 | 2600 | 485 | 300 | 400 | 200 | 14 | 200 |
| PBO 2041 | 200 | 4100 | 6x4100 | 3500 | 485 | 300 | 400 | 200 | 14 | 200 |
| PBO 2531 | 250 | 3100 | 10x3100 | 2600 | 565 | 350 | 450 | 170 | 12 | 170 |
| PBO 2541 | 250 | 4100 | 8x4100 | 3500 | 565 | 350 | 450 | 170 | 12 | 170 |
| PBO 3231 | 325 | 3100 | 12x3100 | 2600 | 565 | 350 | 450 | 170 | 12 | 170 |
| PBO 3241 | 325 | 4100 | 10x4100 | 3500 | 565 | 350 | 450 | 170 | 12 | 170 |

* Other Models are available on Request



CNC PRESS BRAKE

TANDEM / TRIDEM CNC PRESS BRAKES

SOLUTIONS FOR

- ▶ LIGHTING POLES
- ▶ WIND MILLS
- ▶ STEEL TOWER INDUSTRY
- ▶ AUTOMOBILE INDUSTRIES
- ▶ RAILWAY & INFRASTRUCTURE

SALIENT FEATURES

- ▶ The TANDEM / TRIDEM press brakes are the combination of two or more press brakes synchronized by one controller
- ▶ Facility to use both or Individual to improve production efficiency
- ▶ Longer bending jobs, Higher tonnage machines with simple construction
- ▶ Add on options are available
- ▶ Various sheet handling accessories are available



CNC PRESS BRAKE

RANGE | 100 MT to 2000 MT
LENGTH | 3100 mm to 10000 mm

MAGNUM
CNC PRESS BRAKES

HUGE | ENORMOUS

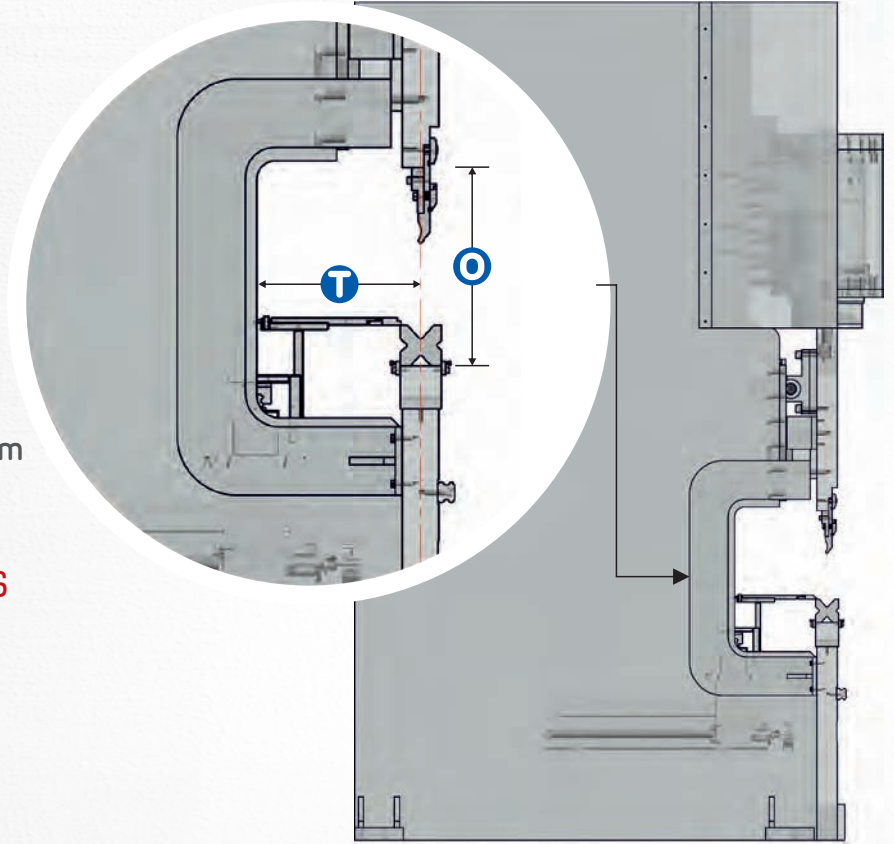

► SALIENT FEATURES

- ♦ Higher Daylight
- ♦ Higher throat depth
- ♦ Higher Stroke length
- ♦ Designed to meet deeper & complex bending requirements
- ♦ Rigid upper beam guide on 12-point roller bearings
- ♦ Ultrasonically & tensile tested IS:2062 grade steel structure ensures the rigidity & avoid deflection
- ♦ The frame is machined on Floor Boring Machine ensuring single reference accurate machining
- ♦ Quick release clamps
- ♦ Back gauge assembly included ball screw, AC Servo drive, LM guides & timer belt
- ♦ Back gauge fingers mounted on LM guide
- ♦ Quick 'V' groove change over with self centred die with rail
- ♦ Hardened & grounded 2'V'/4'V' die & semi gooseneck punch
- ♦ Front sliding sheet support with LM guides for easy movement

OPTIONAL ACCESSORIES



Manual Crowning



Automatic Single / Bi-Directional Crowning

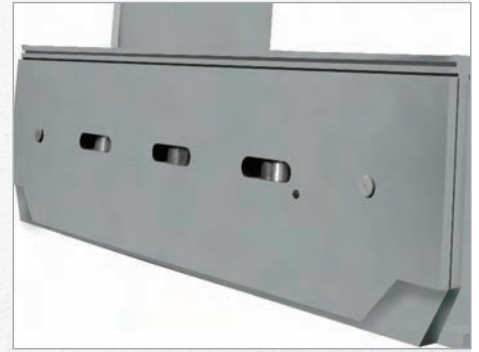

Hydraulic Crowning

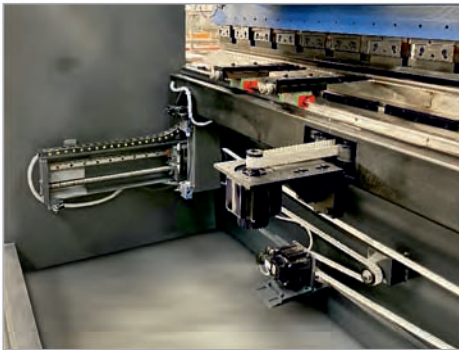

X + R Axis Back Gauge

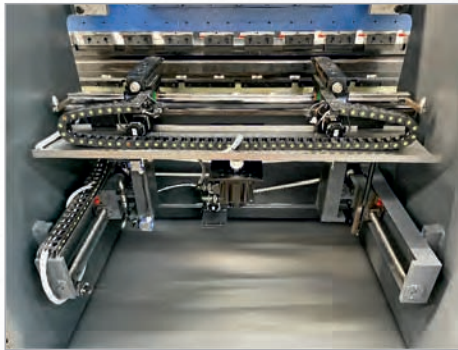

X + R + Z1-Z2 Axis Back Gauge



X1-X2 + R1-R2 + Z1-Z2 Axis Back Gauge

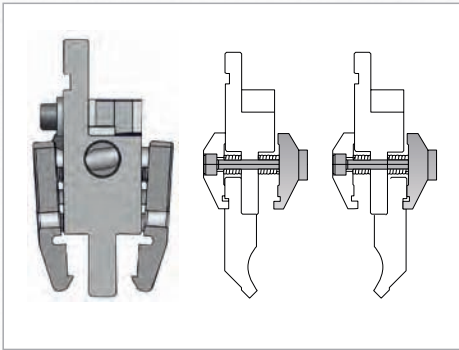

Double Side Mounting Punch Clamp



Stress Relieved Structure



Laser beam operator safety Integrated with press brake controller

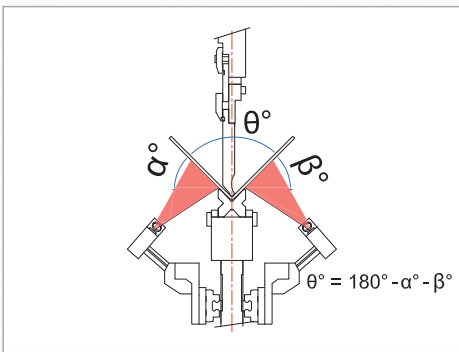

Automatic Angle Measurement



Robotic Arm

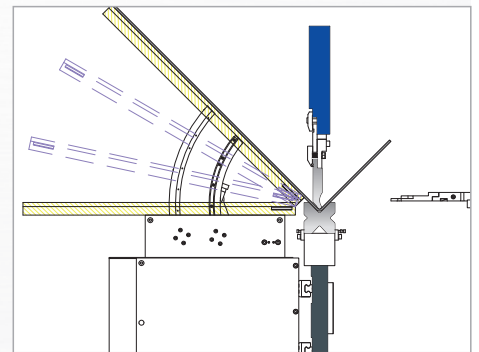

Sheet Follower



CONTROLLERS

LEVEL : 1

4 + 1 AXIS
(NUMERICAL
PROGRAMMING)



ESA S 630



CYBELEC CYB TOUCH 8PS



DELEM DA 53 T

LEVEL : 2

4 + 1 AXIS
(2D GRAPHICAL
PROGRAMMING WITH
MANUAL BEND SEQUENCE)

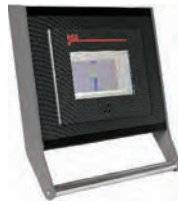

ESA S 630



CYBELEC CYB TOUCH 8PS



DELEM DA 53 T

LEVEL : 3

4 + 1 AXIS
(2D GRAPHICAL
PROGRAMMING WITH
AUTOBEND SEQUENCE)

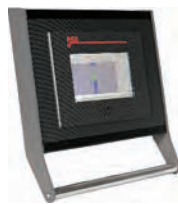

ESA S 630



CYBELEC CYB TOUCH 12 PS



DELEM DA 58 T

LEVEL : 4

6 + 1 AXIS
(2D GRAPHICAL
PROGRAMMING WITH
AUTOBEND SEQUENCE)



ESA S 640



CYBELEC CYB TOUCH 15PS



DELEM DA 66 T

LEVEL : 5

MULTI AXIS
(2D GRAPHICAL
PROGRAMMING
& 3D VISUALIZATION)

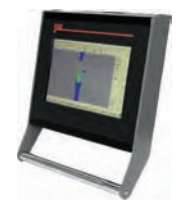

ESA S 650

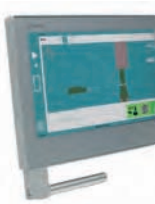

CYBELEC VISIPAC & VISITOUCH 19



DELEM DA 66 T

LEVEL : 6

MULTI AXIS
(3D GRAPHICAL
PROGRAMMING
WITH 3D VISUALIZATION)



ESA S 660

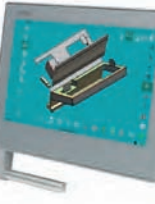

CYBELEC VISITOUCH 19 MX



DELEM DA 69 T

CROWNING SYSTEM

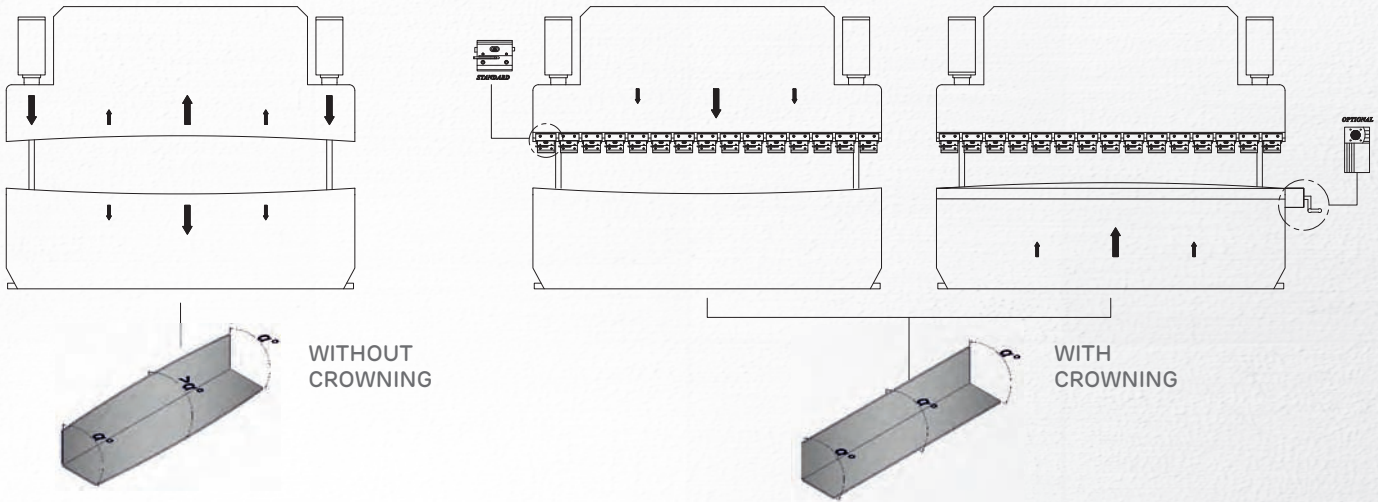

With press brakes, the machine frames tend to deflect during the bending process. Without correction, the top tool does not penetrate the bottom die as deeply across the machine length, especially towards the centre of the press brake. As a result, the bending angle is not constant over the entire length. Crowning systems are characterized by their extremely compact design without any externally moving parts. Control often takes place automatically via a CNC drive motor integrated to the machine controller, eliminating the need for the press brake operator to make adjustments for machine deflection.

The crowning system is intended to overcome the deflection of structure. It is mounted on the bed (lower

beam) of the machine, designed to include stacks of mechanical wedges that could be increased or decreased in height, predominantly in the centre of the machine. This makes it possible to increase or decrease the curve in the crowning system to match the natural curve that was the result of deflection in the ram when the machine came under a load.

CNC Crowning ensures the ram and table are parallel during the bending operation. Sheet thickness, Length, Die Opening, and tensile Strength data are entered into the controller. Force and related deflection of the table and ram are automatically determined, preloading is optimally obtained for each bend.

BENDING FORCE CHART

| t/V | 4 | 6 | 8 | 10 | 12 | 16 | 20 | 25 | 32 | 40 | 50 | 63 | 80 | 100 | 125 | 160 | 200 | 250 |
|----------|-----|-----|-----|-----|-----|------|-----|------|-----|-----|------|-----|-----|-----|------|-----|-----|-----|
| H (min) | 3 | 4 | 5.5 | 6.5 | 8 | 10.5 | 13 | 16.5 | 21 | 26 | 32.5 | 41 | 52 | 65 | 81.5 | 104 | 130 | 163 |
| Ri (min) | 0.5 | 0.8 | 1 | 1.3 | 1.5 | 2 | 2.5 | 3.2 | 4.4 | 5 | 6.5 | 8 | 10 | 12 | 15 | 20 | 25 | 37 |
| 0.5 | 4 | 3 | 2 | | | | | | | | | | | | | | | |
| 0.8 | 12 | 7 | 5 | 4 | | | | | | | | | | | | | | |
| 1.0 | | 11 | 8 | 6 | 5 | | | | | | | | | | | | | |
| 1.2 | | 18 | 12 | 9 | 7 | 5 | | | | | | | | | | | | |
| 1.5 | | | 21 | 15 | 12 | 8 | 6 | | | | | | | | | | | |
| 2 | | | | 30 | 23 | 16 | 12 | 9 | | | | | | | | | | |
| 2.5 | | | | | 39 | 27 | 20 | 14 | 11 | | | | | | | | | |
| 3 | | | | | | 43 | 31 | 23 | 16 | 12 | | | | | | | | |
| 4 | | | | | | | 60 | 44 | 32 | 23 | 18 | | | | | | | |
| 5 | | | | | | | | 76 | 54 | 39 | 23 | 22 | | | | | | |
| 6 | | | | | | | | | 85 | 62 | 45 | 33 | 25 | | | | | |
| 8 | | | | | | | | | | 121 | 88 | 70 | 46 | 35 | | | | |
| 10 | | | | | | | | | | | 151 | 109 | 79 | 58 | 44 | | | |
| 12 | | | | | | | | | | | | 173 | 124 | 91 | 66 | 50 | | |
| 15 | | | | | | | | | | | | | 213 | 155 | 113 | 81 | 62 | |
| 20 | | | | | | | | | | | | | | 302 | 220 | 158 | 115 | 89 |
| 25 | | | | | | | | | | | | | | | 378 | 269 | 187 | 144 |

For SS U.T.S. 72 kg/mm²
Multiply Force by 1.6

The force required for air bending can be calculated from the following formula:
Load, P = $\frac{K \cdot L \cdot S \cdot t^2}{1000V}$ Metric Tones



CONTROL TECHNOLOGY

The CNC Press Brake is a modern press brake with precise automation & state of art technology for achieving best results on fabrication jobs.

It eliminates the need of adjusting bending degrees & marking of bending positions on job. The operator can make program with different degrees & different gauge position. In turn, we can save the time on material handling & job marking. The operator can finish the complete job in one sequence even if different bending degrees & different edge dimensions are required. Hence it is enhancing the productivity of machine. It can save total 200 product programs & each program having 24 bends. These programs can be saved & recalled again for future use.

THE UNIQUE FEATURES OF CNC CONTROLLER PRESS BRAKE OFFERS

- ♦ Highly precise & accurate Bending results
- ♦ Quick & Easy programming
- ♦ The program can be made as simple as reading the job drawing.
- ♦ Complex bending sequence in one go
- ♦ Low maintenance cost
- ♦ Higher productivity & Saving on labour
- ♦ No skilled labour requirement for accurate bending
- ♦ Easy to make samples for special jobs

BEAM CONTROL

The CNC controller has Y1-axis & Y2-axis of Beam control at both ends. The beam axes Y1 & Y2 are synchronized axes. The servo hydraulics is used for controlling the ram parallelism very precisely. Two linear encoder (Y1-Y2) are mounted on two sides of machine, they measure the exact distance between the Ram and Worktable, The Encoder are connected to The table, So that the deformation of the side frame dose not influence the position, The Position data is immediately sent to the controller system that calculates and output the control signal for the servo valves. If there is minor position error, two servo valves can be rectified necessarily by CNC System, it always ensure parallelism statues between the ram and tables.

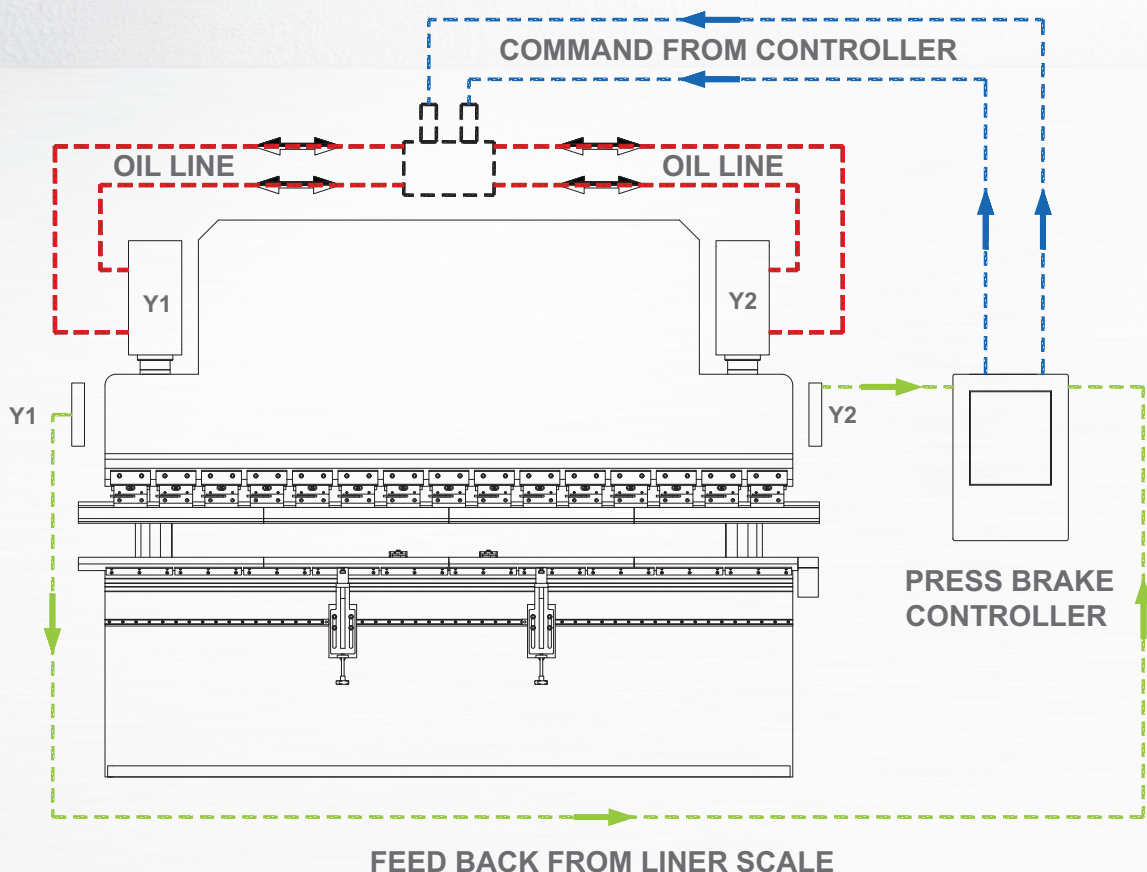

EFFICIENT

SPLENDID

OPTIMA

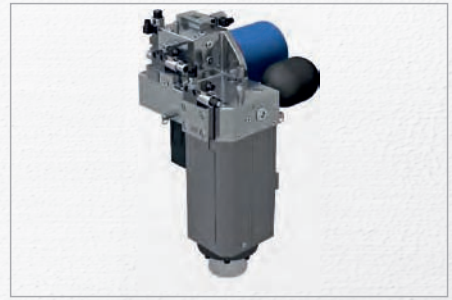

- ▶ 40% Energy Saving with Servo motor Package
- ▶ High Speed beam movements with less power
- ▶ Silent Operations & No oil heating

ENERGY SAVING

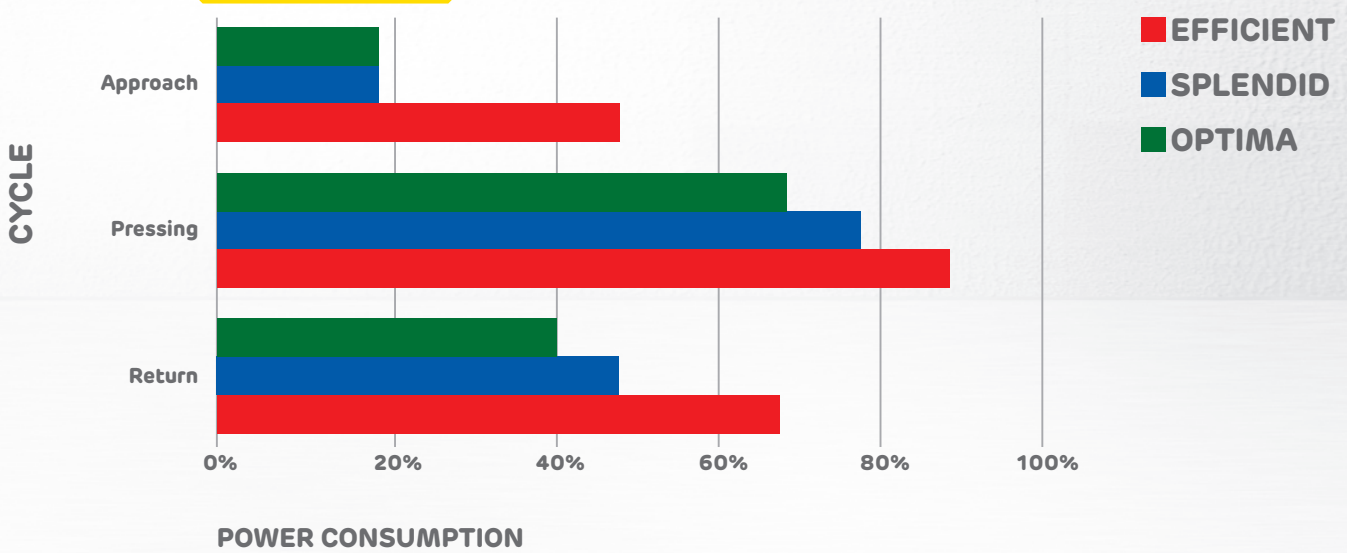

SPEED

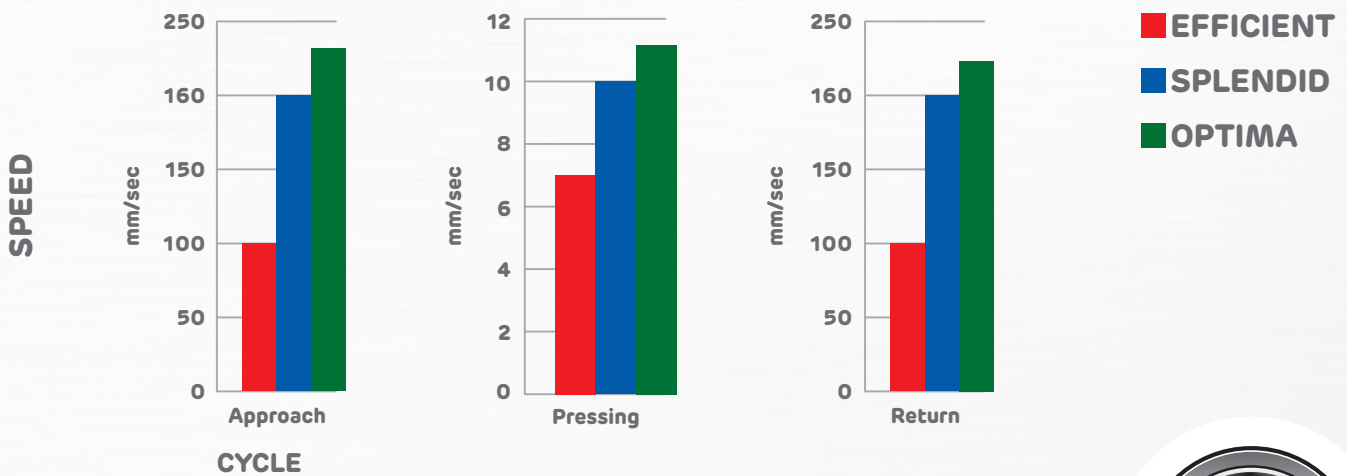

BENDING FORCE CALCULATION (METRIC TONES)

HYDRAULIC PRESS BRAKE MACHINE

The capacity of Press Brake is generally defined in tons. Followings contain the details of load calculation in different types of bending methods like Air Bending, Bottoming, Forming etc. There are certain special applications like piercing, straightening etc, which can also be used on press brakes. But these processes need special tools and different load calculations.

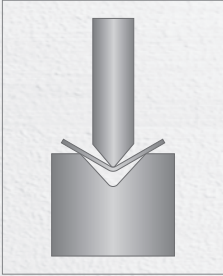

AIR BENDING

Air Bending is the most widely used application on press brake. Air Bending is done on three contact lines, two die edge & cone punch edge. The calculation for air bending is as per following.

| T Sheet Thickness in MM | 0.5mm-8mm | 9mm-10mm | 12mm or More |
|-------------------------|-----------|----------|--------------|
| V - Die Opening | 8T | 10T | 12T |

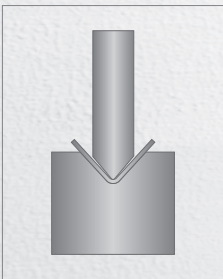

BOTTOM BENDING

In bottom bending the upper and lower dies are usually made with an include angle of 90 degree to ensure sharp corners on the formed part, In the forming process, the dies strike solidly and squeeze the material at stroke bottom.

This process requires 3 to 5 times the tonnage needed in air bending. Since more tonnage is required bottoming is seldom performed on steel greater than 12 gauge.

The adjustable "V" die opening for bottoming are : V=5 to 6x material thickness

PRESS BRAKE SELECTION GUIDELINES

The basic factors to be considered while selecting a press brake, or calculating the correct setting for operation are:

| PARAMETERS | UNIT |
|--|-----------------------|
| Plate Thickness (t) | mm |
| Ultimate Tensile Strength of Plate (S) | Kg/mm ² |
| Aluminum | 25 Kg/mm ² |
| Mild Steel | 45 Kg/mm ² |
| Stainless Steel | 72 Kg/mm ² |
| Bending Length(L) | mm |

| PARAMETERS | UNIT |
|------------------------------|----------|
| Die Opening (V) | mm |
| Minimum Internal Radius | mm |
| Minimum Flange (H) | mm |
| Bending Correction Force (K) | 1.3 |
| Required Tonnage (P) | M. Tones |

THE FORCE REQUIRED FOR AIR BENDING CAN BE CALCULATED FROM THE FOLLOWING FORMULA

$$\text{Load, P (Metric Tones)} = K \times L \times S \times t^2 / 1000 \times V$$

Suppose we want to bend 3.15 mm MS (10 Gauge) in 3000mm length, Following are the Calculation.

$$P = 1.3 (K) \times 3000\text{mm} (L) \times 45 (S) \times 3.15^2 / 1000 (24\text{mm}) = 72 \text{ Metric Tones}$$

Suppose if we want to bend 3.15 mm SS (10 Gauge) in 3000mm length, Following are the Calculation.

$$P = 1.3 (K) \times 3000\text{mm} (L) \times 72 (S) \times 3.15^2 / 1000 (24\text{mm}) = 115 \text{ Metric Tones}$$

The bending chart also gives the bend radius & minimum bend edge also. The bending chart defines the load required per mm thickness per meter. To use bending chart, select the "V" opening from upper most line and thickness from vertical line, the matrix shows the total load in tons per meter. To achieve total load, this value should be multiplied by the total length of job.

TOOL PROFILE

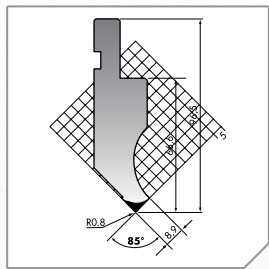
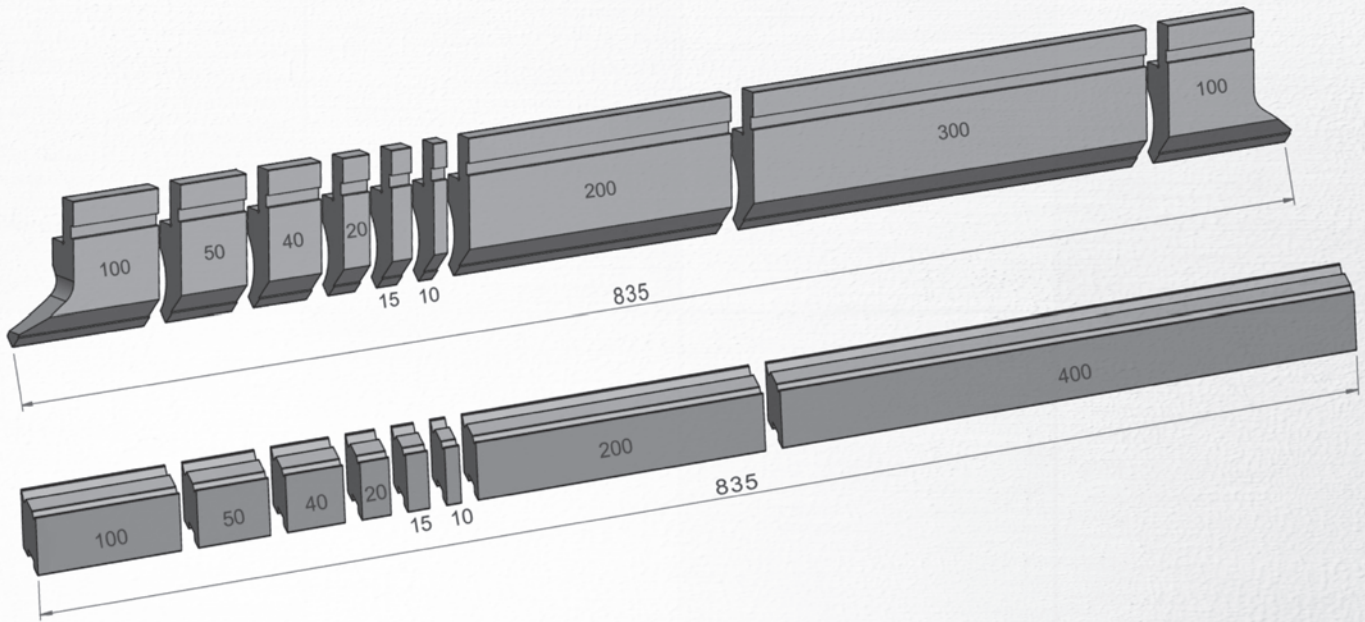

Standard Punch

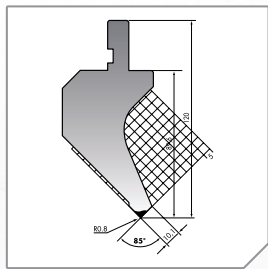

Goose Neck Punch

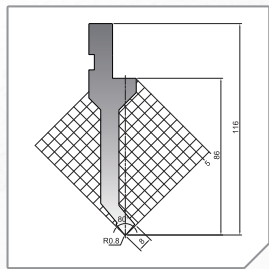

Narrow Punch

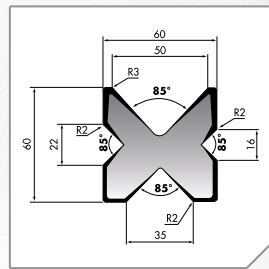

4 "V" Die

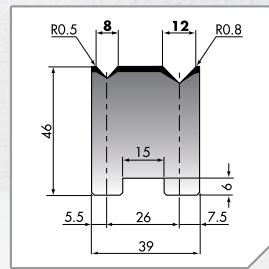

2 "V" Die

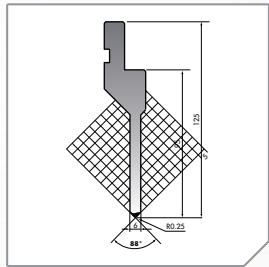

Straight Punch

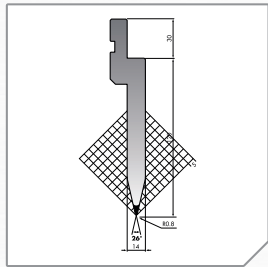

30° Straight Punch

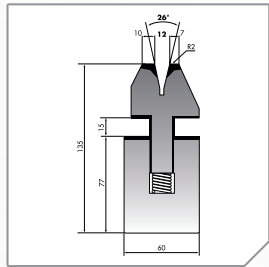

Hamming Die

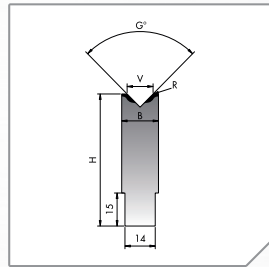

Single "V" Die (Inserted)

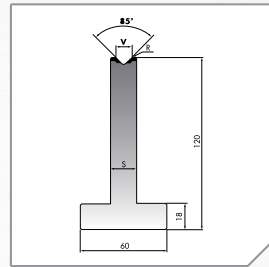

Single "V" T Die

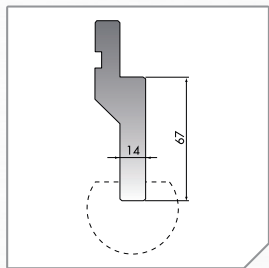

Radius Punch Holder

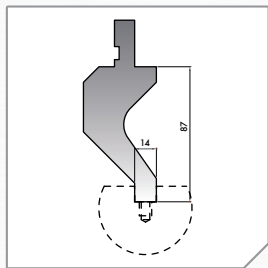

Goose Neck Type Radius Punch Holder

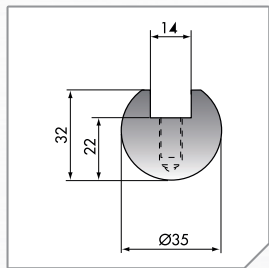

Radius Tool

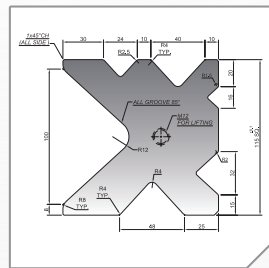

Multi "V" Die

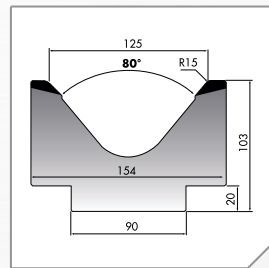

Single "V" Die



NETWORK



Sales Network

Energy Mission Machineries (India) Pvt. Ltd have spread the network across India with presence in various states like Gujarat, Maharashtra, Delhi, Karnataka, Tamil Nadu, A.P., Telangana, Kerala, Uttar Pradesh & West Bengal. We have our team of executives to attend our customers in various cities with aim to provide local sales support. This ensures the in-depth know how about the product and application areas & appropriate selection of products at doorstep.

Apart from Indian territory, we are exporting our products to many countries like UAE, Saudi Arabia, Oman, Bahrain, Qatar, Kuwait, Jordan, Kenya, Uganda, Ghana, Srilanka, Nepal, Bangladesh etc.

Service Network

After sales service is one of the most important aspects of our business ethics. We at energy mission believe to provide prompt and uninterrupted service network to our valued customers. We have established our service centers in various locations like Ahmedabad, Mumbai, Pune, Bangalore, Chennai, Coimbatore, Madurai, Hyderabad, Kolkata, Lucknow & Delhi. As a result of teamwork & quality consciousness, today we have created a most satisfied customer base across India. We have successfully installed more than 5000+ machines working in MNC, Public sector companies, Private Sector Companies & small scale industries.

SOME OF OUR CLIENTS



ACHIEVEMENT



AWARDED AS "OUTSTANDING ENTREPRENEUR OF YEAR" IN YEAR 2008-09 & YEAR 2014-15

ISO 9001 : 2015 CERTIFICATE



NSIC CERTIFICATE

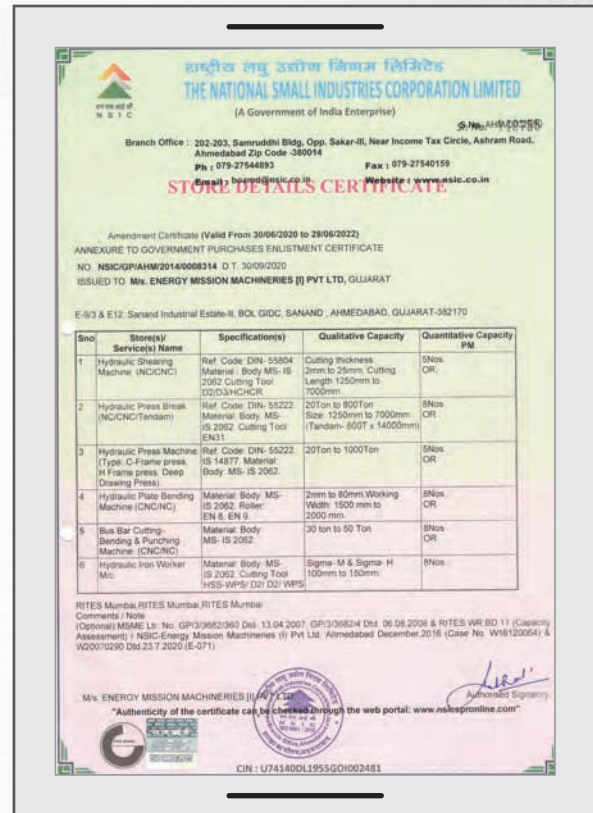



ENERGYMISSION
MACHINERIES (INDIA) PVT. LTD.

 **SCAN FOR LIVE CHAT ▶**
+91 99790 66669



OFFICE : Plot No : 87/1, Phase-I, Opp. Pushpak Industrial Estate, GIDC, Vatva, Ahmedabad - 382445, Gujarat - India.
FACTORY : Plot No : E-9/3, Sanand - II Industrial Area, Bol GIDC, Sanand - 382170, Ahmedabad, Gujarat - India.

MARKETING : +91 98244 81470 | +91 98243 03302
SERVICE : +91 99099 58538
RECEPTION : +91 99244 59591

info@energymission.com | energymission@gmail.com
care@energymission.com
contact@energymission.com | www.energymission.com